

MS-870K

車載用 Car Electronics

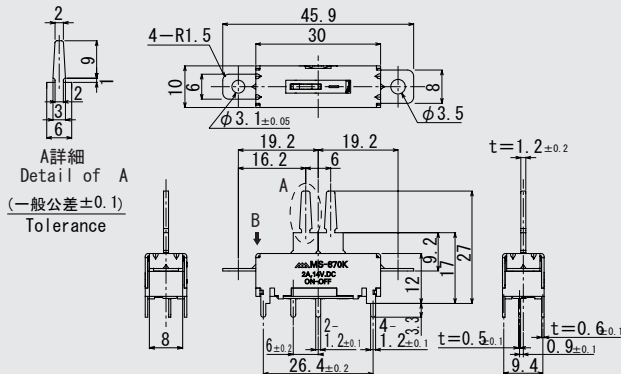

プリント基板取付穴参考寸法図
(B方向より見る)
P.C.Board Mounting Hole Dimensions
(Viewed from the Direction B)

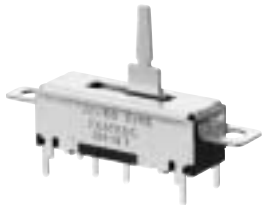
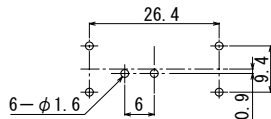

回路図
(B方向より見る)
Circuit Diagram
(Viewed from the Direction B)



品番 PARTS NO.	回路 CIRCUIT	スイッチ特性 SWITCHING FUNCTION	電流容量 RATING	絶縁抵抗 INSULATION RESISTANCE	絶縁耐圧 VOLTAGE BREAKDOWN	接触抵抗 CONTACT RESISTANCE
MS-870K	SPST (2P)	ON-OFF	2A, 14V. DC	DC. 100V 3MΩ以上 (MIN)	AC. 100V 1分間 (Minute)	50mΩ以下 (MAX)